

DUNNAGE RACKS

Dunnage Racks

ALUMINUM / STAINLESS
CONSTRUCTION

Item No. _____

Quantity _____

Job Name _____

Spec No. _____

Applications:

Ideal for any storage application. All welded dunnage racks keep product organized and off of the floor. Prolongs product life by circulating air underneath. 12" height off the ground meets all sanitary health codes. Approved for use in freezers, displays, general storage, and warehouse areas.

Construction:

Heavy duty, high tensile extruded aluminum. Type 6063-T5 alloy. All heli-arc welded construction. Features a lifetime guarantee against rust. Aluminum offers a high level of displacement strength with the added benefit of low weight for safe and easy moving in clean-up projects. Shipped assembled for immediate use.

Lifetime Guarantee.

EXD - Series:

Heavy Duty construction with high tensile aluminum 4" E channel. Sturdy gusset leg design. 3000 lb. distributed weight capacity.

ES - Series:

- All heli-arc welded, 1" Sq. tubular stainless construction.
- 4000 lbs. distributed weight capacity.
- Shipped set up, ready for use.

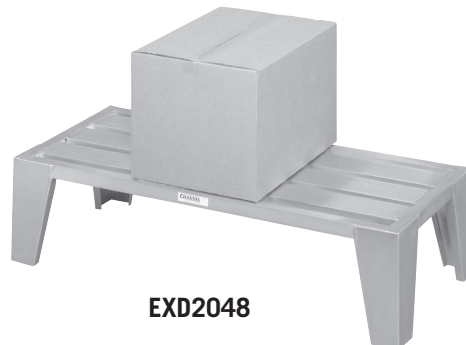

EXD2048

Model	H	W	D	Weight
EXD2036	12"	36"	20"	14
EXD2048	12"	48"	20"	16
EXD2060	12"	60"	20"	18
EXD2436	12"	36"	24"	15
EXD2448	12"	48"	24"	17
EXD2460	12"	60"	24"	19

**LIFETIME
TOUGH**

Custom Sizes
Available

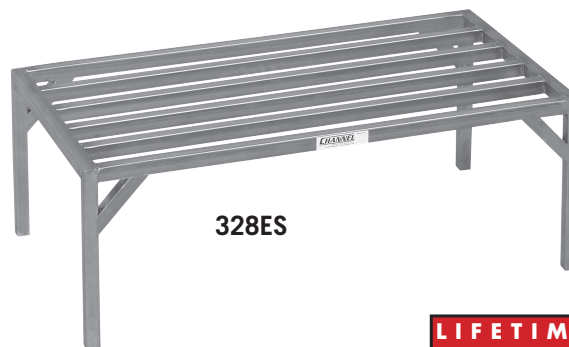

328ES

**LIFETIME
TOUGH**

Tubular Dunnage Rack

Model	H	W	D	Weight
328ES	12"	36"	20"	16
329ES	12"	48"	20"	20
330ES	12"	60"	20"	24

CHANNEL
MANUFACTURING, INC.

55 Channel Drive • Port Washington, NY 11050-2216
8891 NW 102nd Street • Medley, FL 33178
Tel: 516-944-6271 • Fax: 516-944-0625 • Toll Free: 866-712-7283
www.channelmfg.com • Email: sales@channelmfg.com